

DESIGNED FOR USE WITH .141 SR.	
CABLE ENTRY DIAMETER MINIMUM	
CONTACT	.036
CLAMP RING	.115
CLAMP NUT	.144
FERRULE	.153

REVISIONS			
REV	DESCRIPTION	DATE	APPROVED
01 ₂	REVISED	PATLAN 5-04-98	<i>[Signature]</i> 8/24/1998
B	PER EC 0U20-0116-01-05	19NOV01	<i>[Signature]</i> 19NOV01

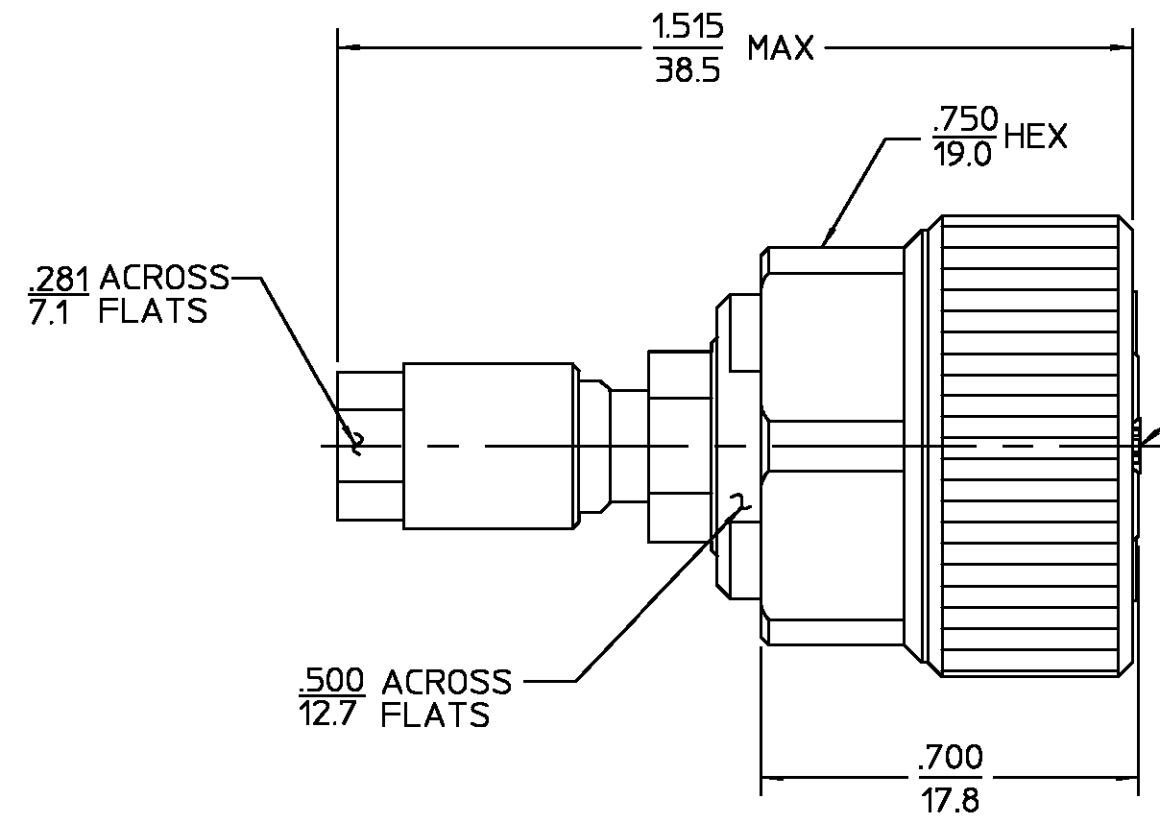

BUSHING	STAINLESS STEEL PER ASTM-A484 AND ASTM- A582, TYPE 303	GOLD PLATE PER MIL-G-45204
COUPLER HSG INNER SLEEVE CLAMP NUT	STAINLESS STEEL PER ASTM-A484 AND ASTM- A582, TYPE 303	ELECTRO-POLISHED
HOUSING CLAMP NUT RIVET	STAINLESS STEEL PER ASTM-A484 AND ASTM- A582, TYPE 303	PASSIVATE PER QQ-P-35
DIELECTRIC	PTFE FLUOROCARBON PER ASTM-D-1457	N/A
CONTACT EXT. & PLUG. HSG.	BERYLLIUM COPPER PER ASTM-B-196 OR ASTM-B-197, ALLOY C17300, CONDITION H	GOLD PLATE PER MIL-G-45204
FERRULE	BERYLLIUM COPPER PER ASTM-B-194, ALLOY C17200, CONDITION H	GOLD PLATE PER MIL-G-45204
CENTER CONTACT	BRASS PER ASTM-B-16, HALF HARD	GOLD PLATE PER MIL-G-45204
COMPONENT	MATERIAL	FINISH

UNLESS OTHERWISE SPECIFIED DIMENSIONS ARE IN INCHES	DRAWN BY GK	DATE 03-02-79	AMP AMP Incorporated 140 Fourth Avenue Waltham, MA 02451-7599	
	CHECKED BY CBH	03-02-79		
	APP'D BY GH	03-02-79		
FRAC. ± 1/64	DEC. ± .005	ANGLES ± 1°	USE ASSY PROCEDURE	TITLE 7mm STRAIGHT CABLE PLUG CLAMP ATTACHMENT
These drawings and speci- fications are the property of M/A COM Interconnect Div. and shall not be reproduced or copied or used in whole or in part as the basis for the manufacture or sale of item(s) without written permission.			NO. A.P. 408-04879 (70-001)	SIZE B CODE IDENT NO. 26805 SCALE 3:1
			7301-5038-02	REV 01 ₂
			SHEET 1 OF 1	

NOTES:
1. CAPTURED CENTER CONTACT

.XXX = in
XX.X = mm (REF)